

DETAIL A
SCALE 1 : 5

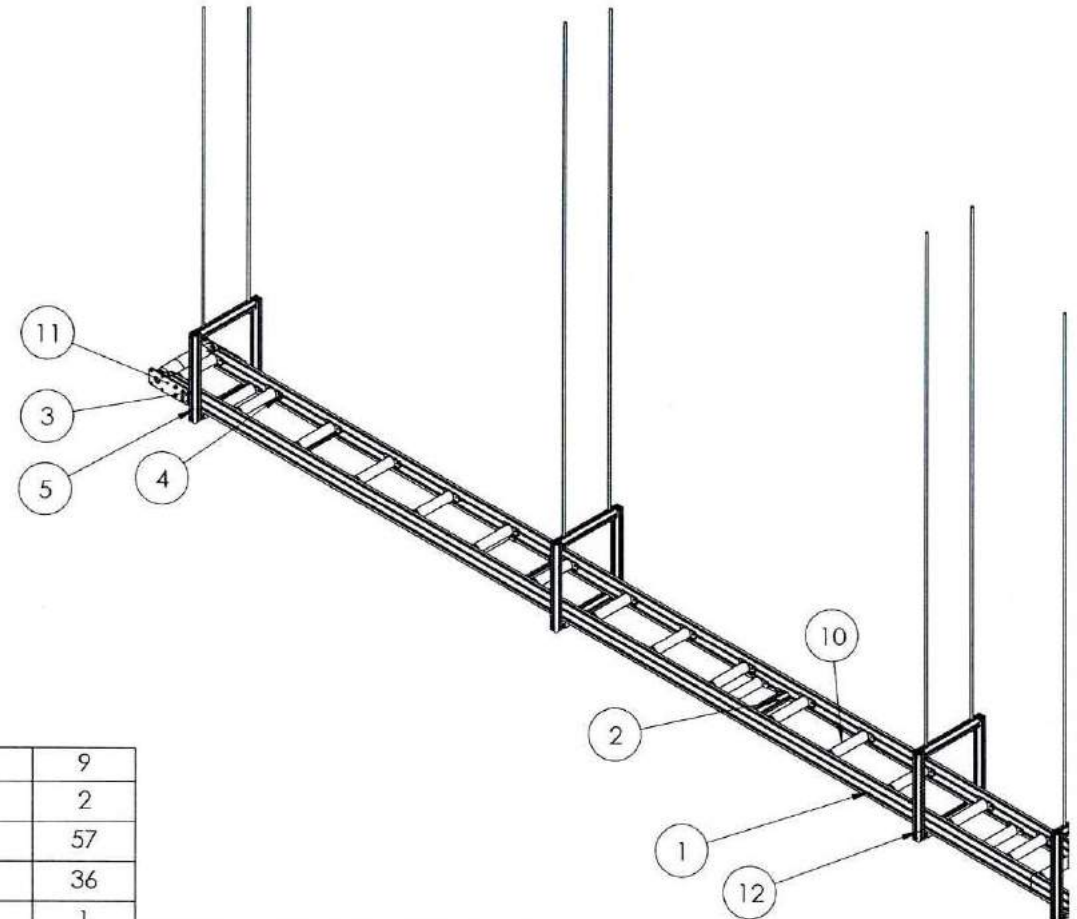

12	KV120-BFS-130-00	assembly support	AL	9
11	KV120-BFS-120-00	Drive Assembly	Various	2
10	KV120-BFS-110-00	Assembly Roller	Various	57
9	KV120-BFS-100-09	Support	AL	36
8	KV120-BFS-100-08	PlexiGlass	pleksiglas	1
7	KV120-BFS-100-07	L40*40(Angle)	AL	4
6	KV120-BFS-100-06	plate 230*90*10	ST37	2
5	KV120-BFS-100-05	support	ST37	4
4	KV120-BFS-100-04	support Roller	ABS	114
3	KV120-BFS-100-03	T Nut	ST37	14
2	KV120-BFS-100-02	profle 40*40	AL	9
1	KV120-BFS-100-01	profile 95*45	AL	6
ITEM	DWG No. / STANDARD	DESCRIPTION	MATERIAL	QTY.

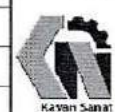

Kavan Sanat Behin
ENGINEERING CO.

DRAWING NO: KV120-BFS-100-00 DRAWING NAME: Horizontal conveyor	Client:	Tolerance:	QTY:	SIZE
		DIN7168M DIN7168T	1	A3
PROJECT NAME: BFS Line ASSY. Name: 	Surface Roughness:	SCALE:	MATERIAL	WEIGHT
		1:100	Material <not specified	325.02 (Kg)
DESIGN: F.TOHIDI	DRAWN: F.TOHIDI	CHECK: F.TOHIDI	APPROVE: M.Soltani	Date: 22/06/07
SHEET:				1 OF 3
REV:				1
RH				AS DRAWN
LH				MIRROR

This drawing is issued solely on the understanding that it is copyright and to be regarded as confidential. It must not be used or reproduced without the prior written consent of the company "Kavan Sanat".

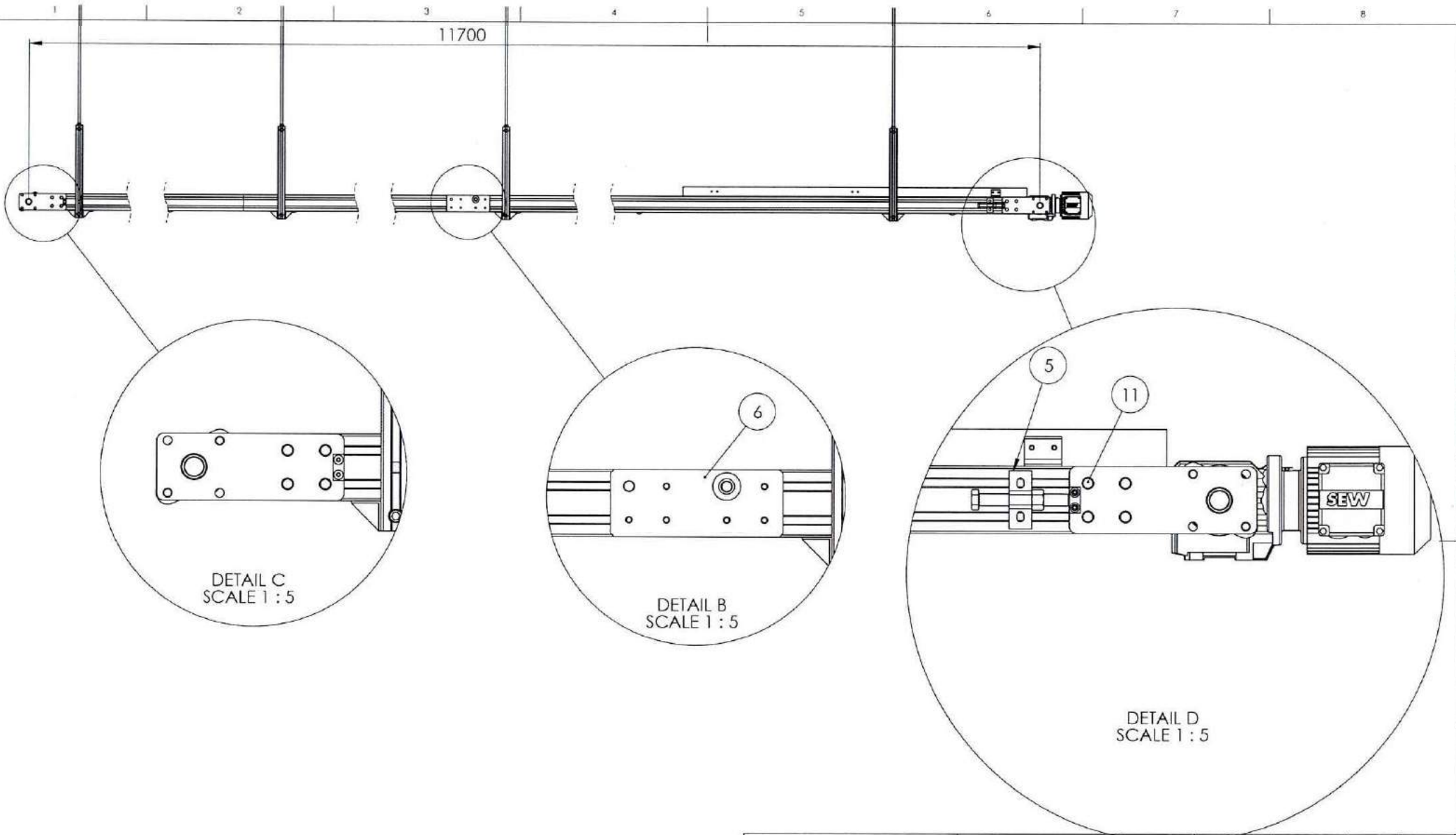

DETAIL C
SCALE 1 : 5

DETAIL B
SCALE 1 : 5

DETAIL D
SCALE 1 : 5

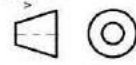
 Kavan Sanat Behin ENGINEERING CO.	DRAWING NO: KV120-BFS-100-00				Client:	Tolerance: DIN7168M DIN7168T	QTY: 1	SIZE : A3
	DRAWING NAME: Horizontal conveyor				Surface Roughness:	SCALE: ---	MATERIAL Material <not specified	WEIGHT 325 02 (Kg)
PROJECT NAME: BFS Line	DESIGN: F.TOHIDI	DRAWN: F.TOHIDI	CHECK: F.TOHIDI	APPROVE: M.Soltani	Data:	SHEET: 2 OF 3		
ASSY. Name: _____						REV: 1		RH AS DRAWN LH MIRROR
<small>This drawing is issued solely on the understanding that it is copyright and to be regarded as confidential. It must not be used or reproduced without the prior written consent of the company "Kavan Sanat"</small>								

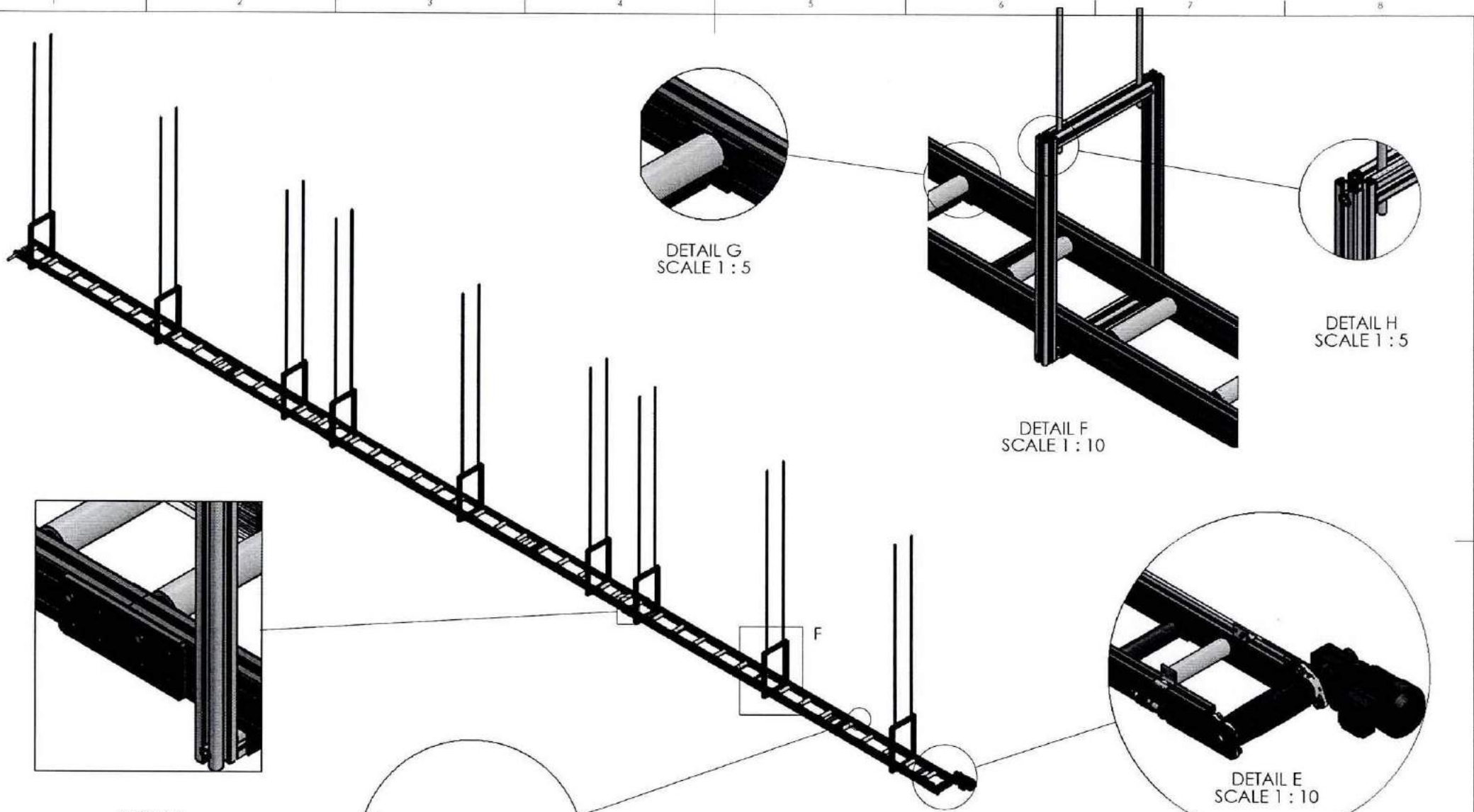

DETAIL G
SCALE 1 : 5



DETAIL H
SCALE 1 : 5

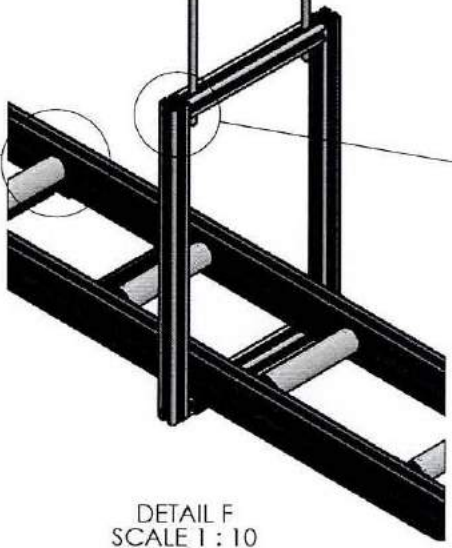

DETAIL F
SCALE 1 : 10



DETAIL E
SCALE 1 : 10

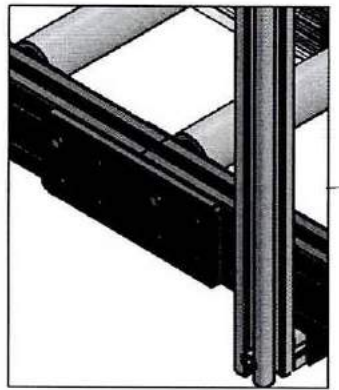

DETAIL I
SCALE 1 : 5

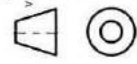

DETAIL J
SCALE 1 : 5

 Kavan Sanat Behin ENGINEERING CO.	DRAWING NO: KV120-BFS-100-00				Client: IKH.CO	Tolerance: DIN7168M DIN7168T	QTY: 1	SIZE : A3
	DRAWING NAME: Assy.				Surface Roughness: ---	SCALE: ---	MATERIAL Material not specified	WEIGHT 343.14 (Kg)
PROJECT NAME:	DESIGN: F.TOHIDI.TOHIDI	DRAWN:	CHECK: F.TOHIDI	APPROVE: M.Soltani	Data:	SHEET: 3 OF 3		
ASSY. Name: -----	This drawing is issued solely on the understanding that it is copyright and to be regarded as confidential. It must not be used or reproduced without the prior written consent of the company "Kavan Sanat"					REV: 1	RH LH	AS DRAWN MIRROR

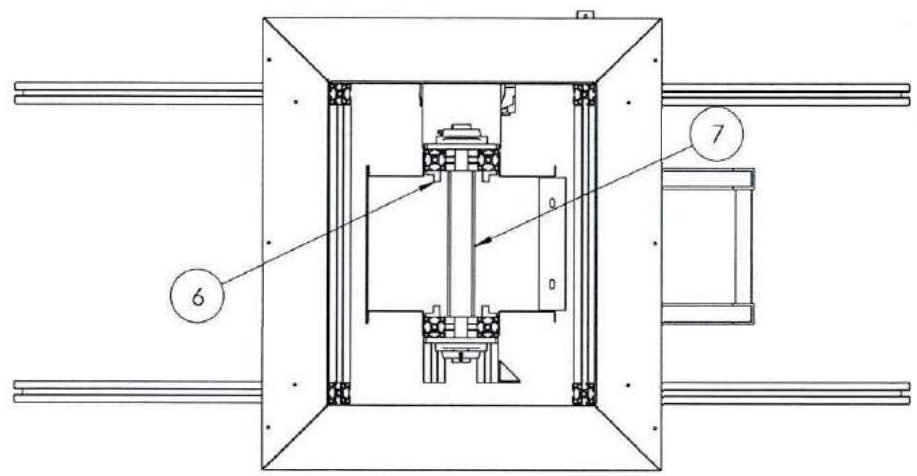
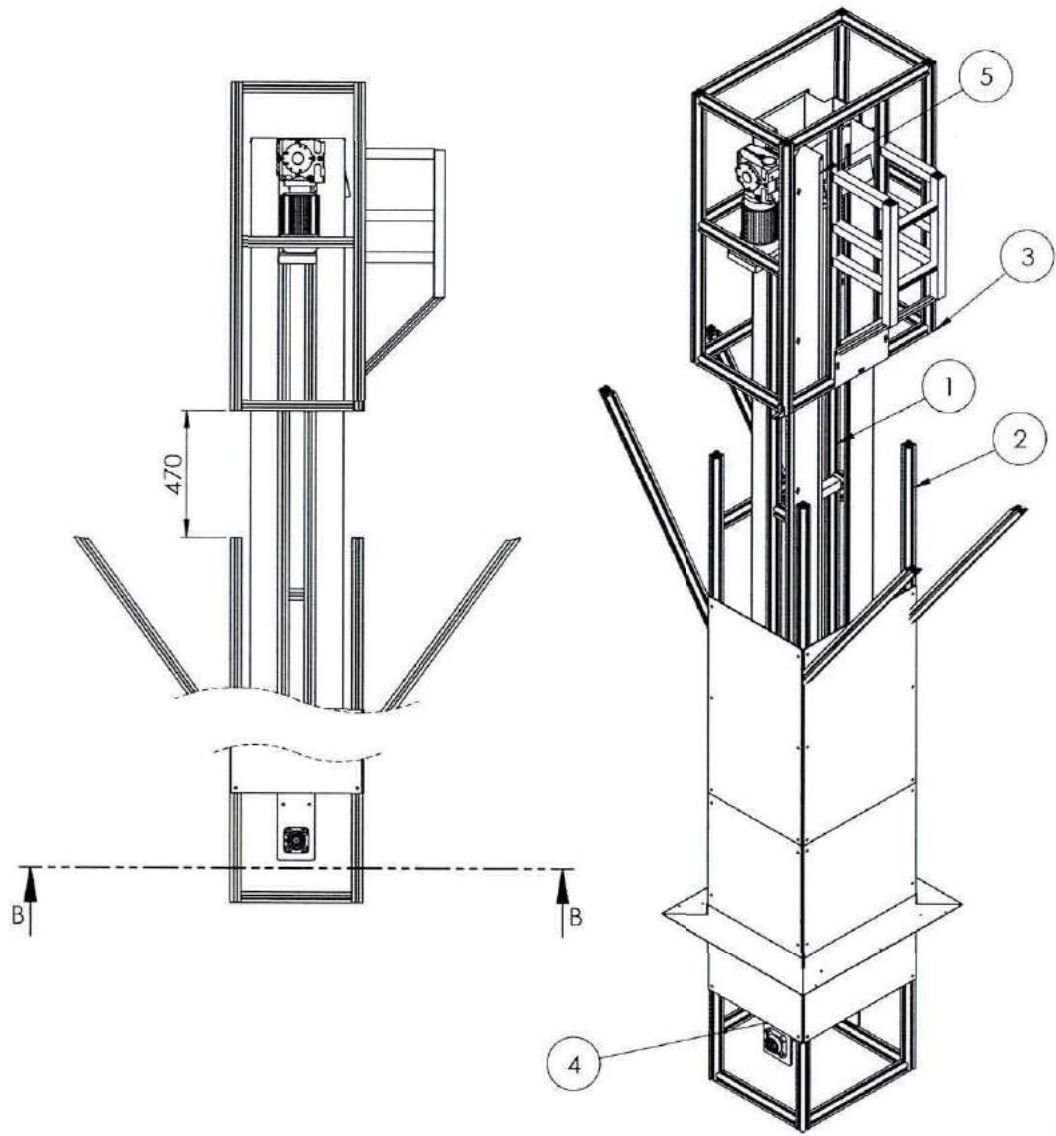



SECTION B-B
SCALE 1 : 10

7	KV120-BFS-300-04	Motor Shaft	Steel	1
6	KV120-BFS-300-03	Chain Guide	PPE	4
5	KV120-BFS-300-02	Guide	Steel	4
4	KV120-BFS-300-01	Plate Motor	ST37	4
3	KV120-BFS-330-00	Shooting Assembly	AL	1
2	KV120-BFS-320-00	Structure Assembly	AL	1
1	KV120-BFS-310-00	Frame Assembly	AL	1
ITEM	DWG No. / STANDARD	DESCRIPTION	MATERIAL	QTY.

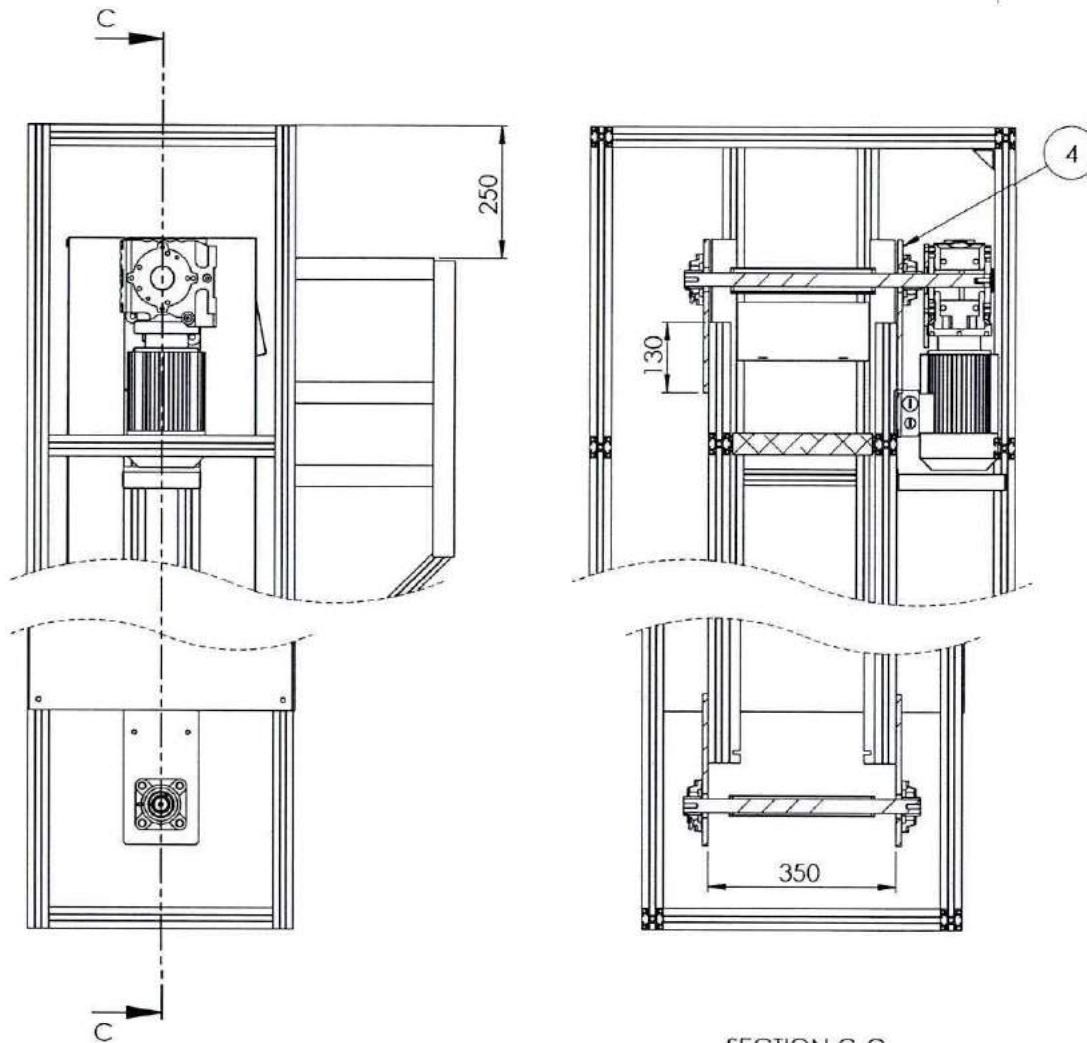
 Kavan Sanat Behin ENGINEERING CO.	DRAWING NO: KV120-BFS-300-00		Client:	Tolerance: DIN7168M DIN7168T	QTY: ---	SIZE: A3
	DRAWING NAME: Modular Vertical conveyor		Surface Roughness:	SCALE: 1:50	MATERIAL Material <not specified	WEIGHT 170.59 (Kg)
PROJECT NAME: BFS Line	DESIGN: H.Nouri	DRAWN: H.Nouri	CHECK: M.Soltani	APPROVE: M.Soltani	Date: 22/06/07	SHEET: 1 OF 3
ASSY. Name: -----	This drawing is issued solely on the understanding that it is copyright and to be regarded as confidential. It must not be used or reproduced without the prior written consent of the company "Kavan Sanat"			REV: 1	RH LH	AS DRAWN MIRROR



SECTION C-C
SCALE 1 : 10

 Kavan Sanat Behin ENGINEERING CO.	DRAWING NO: KV120-BFS-300-00				Client: IKH.CO	Tolerance: DIN7168M DIN7168T	QTY: ---	SIZE : A3
	DRAWING NAME: Modular Vertical conveyor				Surface Roughness: ----	SCALE: ----	MATERIAL Material <not specified	WEIGHT 170.59 (Kg)
PROJECT NAME:	DESIGN: H.Nouri	DRAWN: H.Nouri	CHECK: M.Soltani	APPROVE: M.Soltani	Data:	SHEET: 2 OF 3	 	
ASSY. Name: -----	This drawing is issued solely on the understanding that it is copyright and to be regarded as confidential. It must not be used or reproduced without the prior written consent of the company "Kavan Sanat"					REV: 1	RH LH	AS DRAWN MIRROR

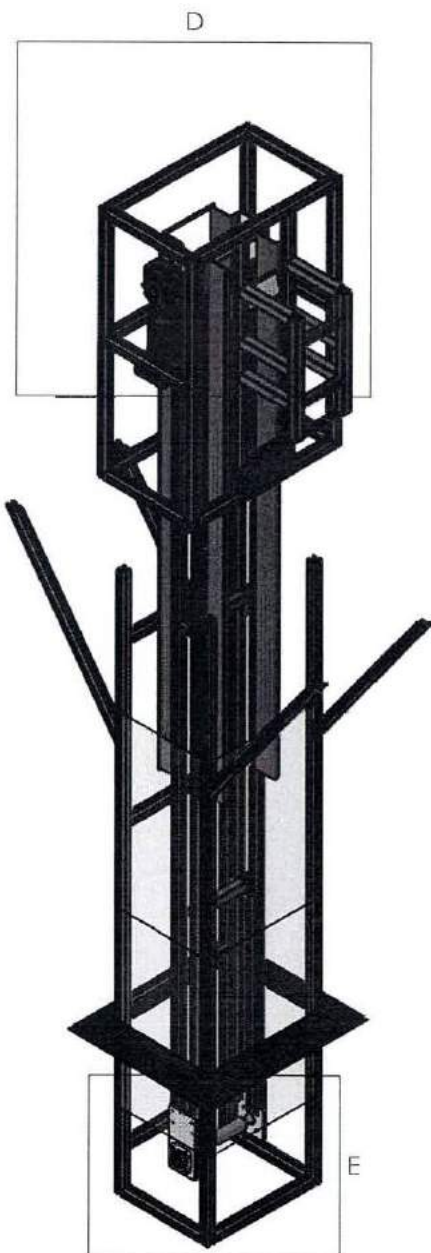

DETAIL E
SCALE 1 : 7

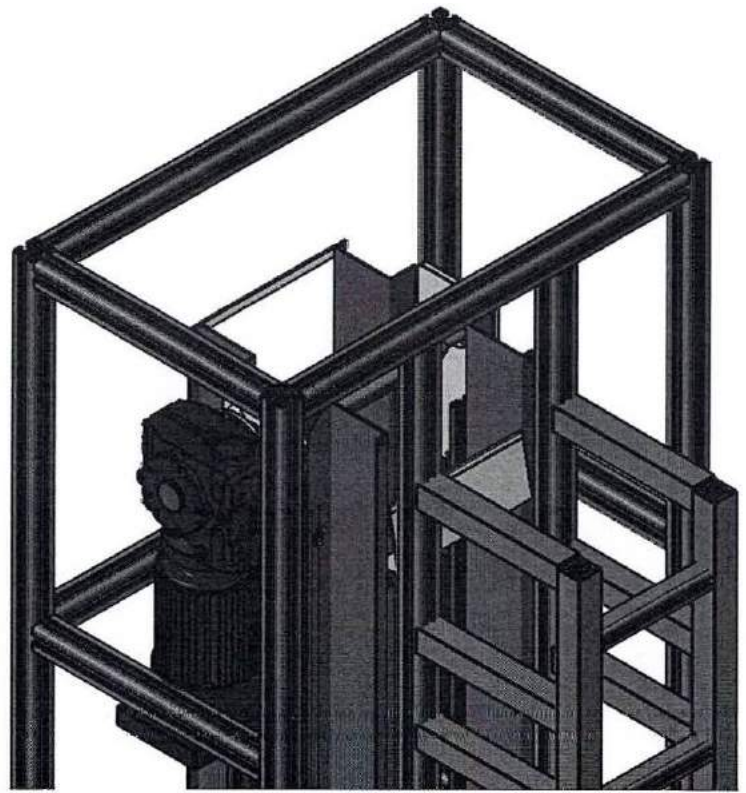
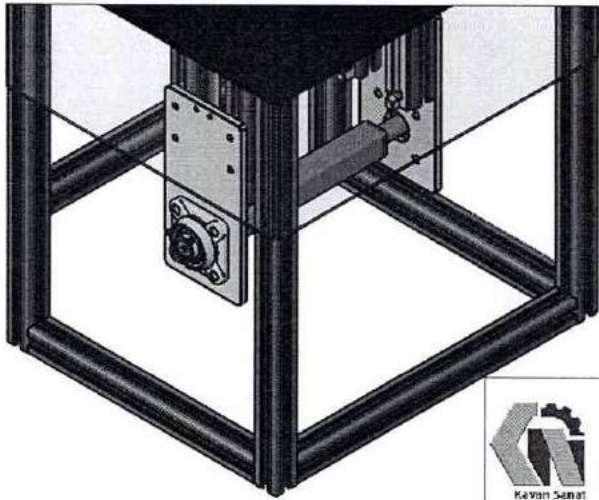

DETAIL D
SCALE 1 : 7



Kavan Sanat Behin
ENGINEERING CO.

DRAWING NO: KV120-BFS-300-00	Client: IKH.CO	Tolerance: DIN7168M DIN7168T	QTY: ---	SIZE : A3			
	DRAWING NAME: Modular Vertical conveyor		Surface Roughness: ---	SCALE: ---	MATERIAL Material <not specified	WEIGHT 170.59 (Kg)	
PROJECT NAME:	DESIGN: H.Nouri	DRAWN: H.Nouri	CHECK: M.Soltani	APPROVE: M.Soltani	Data:	SHEET: 3 OF 3	
ASSY. Name: -----	This drawing is issued solely on the understanding that it is copyright and to be regarded as confidential. It must not be used or reproduced without the prior written consent of the company "Kavan Sanat"				REV: 1	RH AS DRAWN	LH MIRROR